

Facts

megaSun® 6800

Innovations at its best

p2 - Pigment tubes, powerful and gentle at the same time

The fast creation of melanin in the skin provides perfect tanning results. In addition to that vital bio positive effects come into existence as vitamin D3 is built. Your customers can be sure that using p2 tubes results in tanning that is really gentle on the skin.



fourSeasons - drench into a sea of lights

FourSeasons stands for smooth transition from one colour to the next one deriving from the accent illumination of the solarium. Feel the colours of the four seasons on your skin and relax in comfortable warmth and the colours of the rainbow. Trend setting high Power RGB colour LED technology guarantees powerful illumination as well as a long life of approx. 100,000 hours.



electronicPower

Save approx. 33 % energy per tube with this new technology including electronic ballasts. However, eP does not only save money, it helps to keep heat creation at a low level and to reduce the weight of the solarium.



preSelection

More comfort is provided by the glass control panel at the outside of the solarium. The customer can make his/her choice according to his/her preferences and take the time he/she needs to do it **before** tanning. I .e. relaxing sun bathing from the very start. Additional to that, the recesses in the display can be touched easily - even with shut eyes and thus make further operation easy as 1, 2, 3.

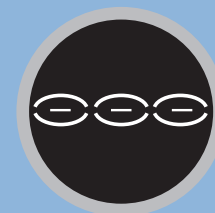

USB Audio

Only megaSun provides a USB connector outside of the canopy of the solarium to plug in USB sticks with the favourite music of your customers.

intelliSun Intelligent tanning powered by cpi

Customers can select between various skin type settings matching her/his level of pigmentation the best. IntelliSun offers the best of the sun for each customer within her/his own tanning level (basic, mediterranean, caribic).

Standard



Optional Features

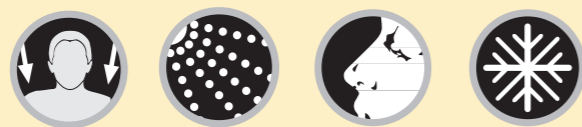

Power Package



Competence Package

easyCare controlled by cpl only in combination with **intelliSun**

Exhaust air duct

Exhaust air hose (Ø 300mm, white, length 3m, 2 hose clamps)

Thermostatic cabin temperature controlling

megaTimer

Models

megaSun 6800	Super	Super Power	Ultra Power	intelliSun (iS)
Reflector tubes Canopy (in watt)	24 x 100 2 x p2	24 x 160 2 x p2	24 x 160 2 x p2	20 x iS 6 x p2
Reflector tubes Bench (in watt)	20 x 100	20 x 120	20 x 160	20 x iS
Facial lamps, adjustable (in watt)	4 x 400	4 x 500	4 x 500	4 x 500
Power output (in watt) (with airCon)	7,200 (8,460)	8,900 (10,160)	9,600 (10,860)	9,600-11,600 (10,860-12,860)
Fuse K-Automat 3 pin 25 amp	20	25	25	25

Unit dimensions

closed
2,380 mm x 1,430 mm x 1,534 mm
(length x width x height)

opened
2,380 mm x 1,430 mm x 1,942 mm
(length x width x height)

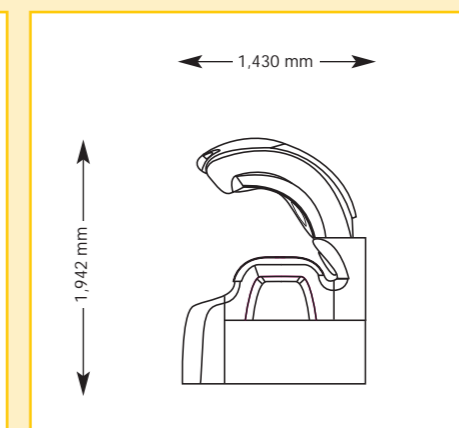
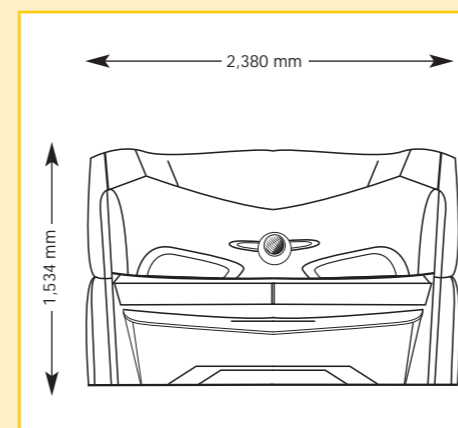

Features



ACS Intelligent technology controls the intensity of the ventilation – depending on the room temperature – and also the noise level. At the beginning of the tanning session ACS ensures a gentle-up of the whole ventilation system; at the end of the session it controls the soft boot-down of the burners, tubes and the complete ventilation and aeration system.



airCon The high performance air-conditioning system guarantees a pleasant cooling during the tanning session on all megaSun-sunbeds.



automatic VolumeControl this feature offers acoustic pleasure on constant level. The volume of the internal and external music players is automatically adapted to the loudness of the environment caused by the ventilating system.



aquaCool Through two special jets in the upper part of the apparatus, which function absolutely drip-free, aquaCool produces a fine mist – refreshing and revitalizing at the same time.



aroma If the customer chooses the aroma function, pleasant aroma concentrates in the two fragrances SUNRISE and DAYDREAM, which increase the feeling of well-being, are sprayed off. In addition to the aroma function, you will automatically get the cabinBreeze which allows you to fill the cabin with a fragrance.



electronicPower a bunch of innovative features – that is electronicPower. Electronic ballasts reduce energy consumption of the tubes by approx. 33% and in addition to that the weight of the solarium by approx. 100 kg. Smooth and safe operation is guaranteed even if the voltage supply is unsteady.



evoSystem² Novel reflectors for maximised balancing of operations. Purpose-built refined surfaces for even higher efficiency. evoSystem2 – Power for a sensation causing, intensive and smooth tan in the facial area. Face the power!



fourSeasons Four Seasons makes it possible to experience all the colours of the rainbow. The changes in colour stimulate the well-being of your customers and make tanning a unique experience. Spring, summer, autumn and winter – experience the sensibility of colour!



megaVoice With megaVoice system you can lay back and relax just from the welcome on. A pleasant voice guides the customer through the manual functions of the solarium: mistakes impossible, well-being guaranteed – just until farewell.



mp3-sound-box + Audio-access "Listen and relax" is the motto of the mp3-sound-box. The mp3-player can be equipped with any kind of music by each studio operator individually. The mp3-player can be connected by using the audio access (also equipped with a headphone access).



musicVibration musicVibration is the megaSun sound system, that makes you feel the vibration of the music. The system generates sound waves from vibration and thus spreads the sound more homogeneous in the tanning tunnel. Feel the elaboration of the sound experience: Feel the music!



preSelection A user friendly display is meant with this feature. It is located at the outside of the canopy. According to personal preferences, features can be selected easily and in a convenient way **before** sunbathing.



pureAir refreshment in the truest sense of the word, that's what pureAir has to offer. Ionized, i.e. cleared air reduces the annoying tanning odours and has a vitalizing, effect on the whole organism.



p2-Pigment-tube p2 – a new type of solarium tubes. Compared to common tubes, this new technology combines perfect tanning results and the formation of vitamin D3. And what is relieving for your customer, it is really gentle on the skin.



USB Audio USB connectors are getting more and more popular. Megasun is meeting this trend and offers USB connectors with the solarium megaSun 6800 as a standard. Customers just connect their own USB sticks loaded with the music they love.



x-traTan Reflector tubes have been used in the past. Today modern high pressure lamps provide extra power and permanent tan in the shoulder area – extra smooth, extra intensive.

www.megaSun.de

KBL-Solarien AG · Sunshine Company · Ringstr. 24-26 · 56307 Dernbach · Germany

fon +49(0)2689.9426-0 · fax +49(0)2689.9426-66 · E-Mail megaSun@kbl.de